

Description of Operation

The 3 phase Simplex Oil Alert is a NEMA 1 (indoor rated) three phase simplex control panel. It's designed to pump water out of elevator sump pits, transformer vaults and leachate wells while containing the oil or hydrocarbons in the pumping tank. The panel operates 208, 230 or 460 VAC pumps. (575 VAC or other voltages are available upon request) Indicator lights on the front door will illuminate if the systems has power, the pump is running, or if there is a high water or high oil alarm (optional pump overload indicators available). The panel and pump are hardwired through conduit. The Preset Level Sensor mounts in the pumping tank or pit.

Electrical Ratings

- 3 Phase
- 1-32 Amps
- 208/230/460V
- 60 Hz.

External Components

- ① 12X10X6 Nema 1 Thermoplastic
- ② Green Power On Indicator
- ③ Amber Pump Run Indicator
- ④ Blue High Water Indicator
- ⑤ Red High Oil Indicator
- ⑥ Preset Level Sensor

Internal Components

- ⑦ IEC Motor Contactor
- ⑧ Motor Protective Switch
- ⑨ Transformer
- ⑩ Terminal Blocks
- ⑪ Ground Lug
- ⑫ UL Listed

Features and Benefits

- Separate alarm & control fuses
- Alarm auto reset
- Load selector switch
- Preset Level Sensor
- Type 4X enclosure and other options available upon request

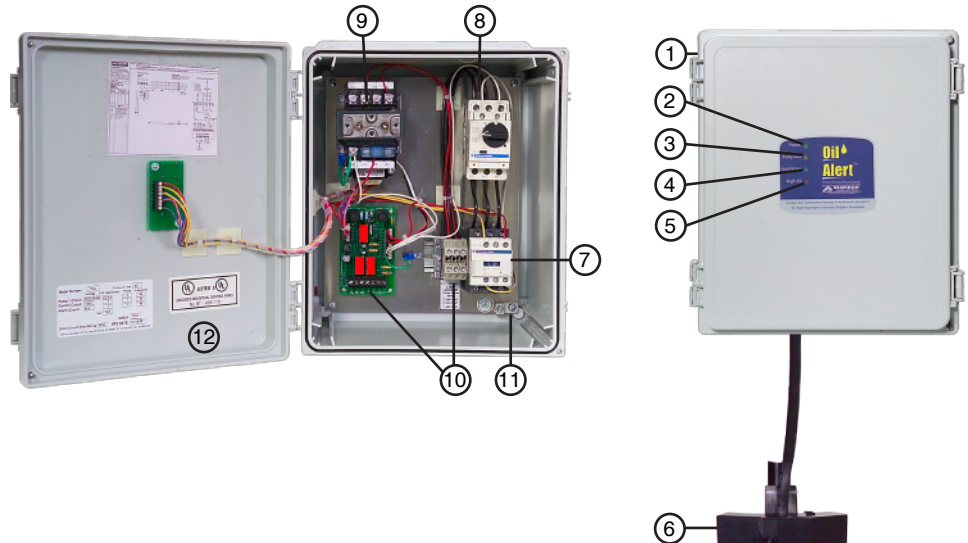

Enclosure Dimensions in inches

Width	Height	Depth	Mounting Holes	
			Width M1	Height M2
11.32	14.08	7.28	8.56	13.34

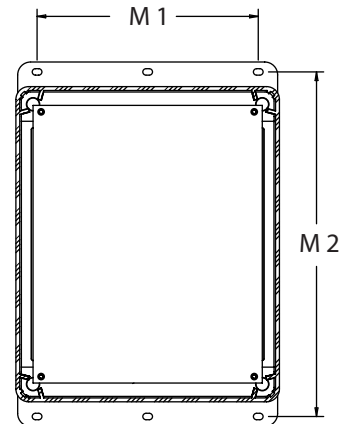
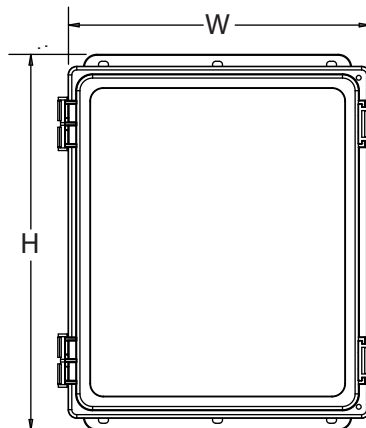
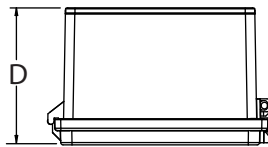

System Overview

On liquid rise, level reaches pump “start” probe to start the pump. Pump will remain on until level is below “off” probe. The “off” probe senses air or oil and turns the pump off so the oil layer will not be pumped

out of the tank. If the level reaches alarm probe and mechanical float, the system will differentiate between water and oil and activate the remote alarm.

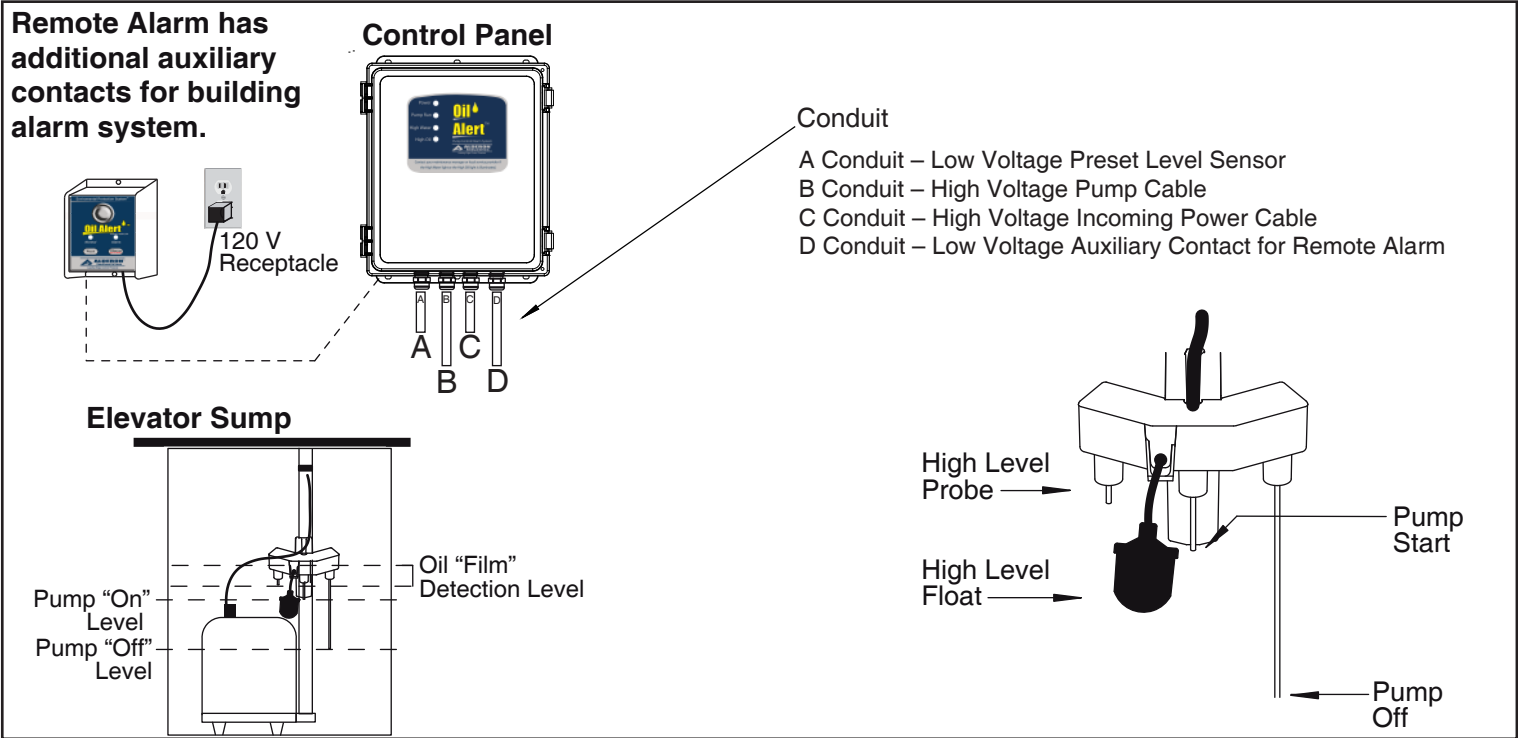

Specifications

Sensor

- ▶ **Housing:** ABS
- ▶ **Probe:** Stainless Steel
- ▶ **Float:** PVC

Control Panel

- ▶ **Enclosure:** Type 1
- ▶ **Voltage:** 208/230/460 VAC

Alarm Panel

- ▶ **Enclosure:** Type 1
- ▶ **Power Cord:** Plug In Transformer, 120 VAC

- ▶ **Backup Power:** 9 VDC Battery Backup
- ▶ **LED Alarm Indicators**
- ▶ **Audible Alarm:** 103 db buzzer, auto test/reset

Order Number



*For Longer Cord Lengths Consult Factory.

Part Number	Description
7855	Oil Alert, 3 Phase, Simplex, 208/230/460 VAC, 1.0-1.6 Amps, Sensor, Remote Alarm
7856	Oil Alert, 3 Phase, Simplex, 208/230/460 VAC, 1.6-2.5 Amps, Sensor, Remote Alarm
7857	Oil Alert, 3 Phase, Simplex, 208/230/460 VAC, 2.5-4.0 Amps, Sensor, Remote Alarm
7858	Oil Alert, 3 Phase, Simplex, 208/230/460 VAC, 4.0-6.3 Amps, Sensor, Remote Alarm
7859	Oil Alert, 3 Phase, Simplex, 208/230/460 VAC, 6.0-10.0 Amps, Sensor, Remote Alarm
7860	Oil Alert, 3 Phase, Simplex, 208/230/460 VAC, 9.0-14.0 Amps, Sensor, Remote Alarm
7861	Oil Alert, 3 Phase, Simplex, 208/230/460 VAC, 13.0-18.0 Amps, Sensor, Remote Alarm
7862	Oil Alert, 3 Phase, Simplex, 208/230/460 VAC, 17.0-23.0 Amps, Sensor, Remote Alarm
7863	Oil Alert, 3 Phase, Simplex, 208/230/460 VAC, 20.0-25.0 Amps, Sensor, Remote Alarm
7864	Oil Alert, 3 Phase, Simplex, 208/230/460 VAC, 24.0-32.0 Amps, Sensor, Remote Alarm