

VERSA'LARM™ Installation Instructions

Warning! Turn off all power when installing or adjusting unit. Failure to turn off all power could result in serious injury or death!
 Read instructions thoroughly.
 Check local codes and install to meet requirements - Refer to National Electrical Code (NFPA 70).
 Alarm unit MUST be mounted indoors, failure to do so will damage unit and void warranty.



Specifications

Mechanical

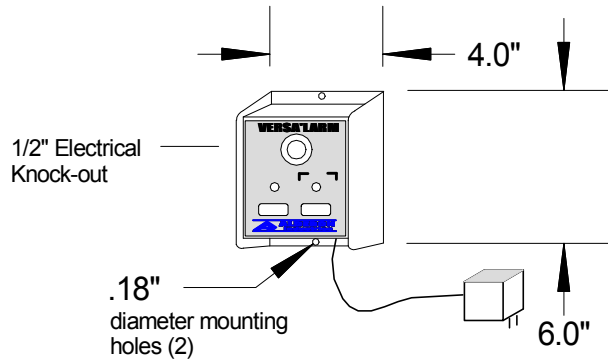

Enclosure Powder Coated Paint for Indoor Use.
 Six Foot Power Cord.
 1/2" Electrical Knock-Out.

Part Number 7001 (Standard)

Electrical

Primary Power: 120 VAC, 50/60 HZ
Secondary Power: Class 2, 9 VDC, 200 ma
Auxiliary Contacts: Single Pole, Double Throw
 Class 2, 24 VDC/24 VAC (50/60HZ),
 500 ma MAXIMUM
Battery: 9 Volts (Not Included)
Buzzer: 103 db @ 2 feet
Switch: UL listed, 9 VDC, 200 ma minimum
 (signaling device) Single Pole, Single Throw

Model Number Nomenclature

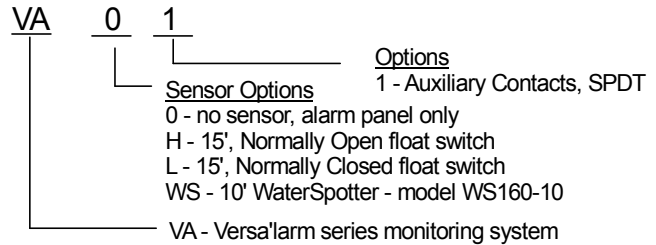

Description of Operation & Maintenance

The VERSA'LARM is a multipurpose alarm that can be used in a wide variety of applications such as: septic tanks, sumps, holding tanks, pump chambers, water tanks, flow, pressure, condensate, temperature and any others where a "dry" contact can be connected to the VERSA'LARM.

The VERSA'LARM is powered by 120 VAC coming from standard wall outlets and is transformed to 9 VDC. Installing a 9 Volt battery provides battery back-up.

When a switch (signaling device) contact "closes" the buzzer and light will turn "on" and the auxiliary contacts will be activated. Pressing the "silence" switch deactivates the buzzer and auxiliary contacts. When the alarm is remedied, the system automatically resets itself.

Test product weekly. Make sure the green "power on" light is "on". Press the "Test" switch, the red alarm light and buzzer should turn "on". If the battery backup system is utilized, unplug the wallmount power supply (the green light will be off). Now press the "Test" switch, the red alarm light and buzzer will turn "on". If the buzzer sounds less loud then when tested with the normal power supply, then replace the battery. Refer to instructions on installing/replacing the battery on page 2. Reconnect power supply when finished to put the Versa'alarm back into service.



VERSA'LARM™ Installation Instructions continued

1. To install/replace the battery for the backup power feature, remove the two side screws and install 9 VDC battery (Duracell model MX 1604B2). After installing battery, press the test button to activate the alarm to make sure the battery works properly. Reinstall side screws. See Figures 1 & 2.
2. Determine mounting location for the VERSA'LARM. Make sure power outlet is within 6 feet of the VERSA'LARM. Make sure the outlet is on a separate circuit breaker from any other device and not on a switched receptacle to maintain power integrity. Mount the VERSA'LARM using two #8 x 1 1/4" self tapping screws(not included). Use #8 plastic anchor if mounting to sheet rock. See Figure 2.
3. If Auxiliary Contacts are used continue, else go to step 4. Remove cover from base and remove 1/2" electrical knockout from base. Use 16 - 2 AWG stranded wire - make sure there is at least 6" of wire inside of enclosure. Install a 1/2" strain relief with jam nut. Connect wires for required application using wire nuts. **Caution!** - When installing wires, route all wires away from sharp objects & internal components. See figures 3A & 3B.
4. Use the included label identification kit or permanent marker/user supplied label to identify the alarm condition. Use the tick marks for alignment. See Figure 2.
5. Connect a UL listed switch (rated 9 VDC, 200 ma MINIMUM) such as a float switch, pressure switch, etc. to the two position terminal block on the VERSA'LARM. One wire per terminal. The alarm is activated by a closed switch. See Figure 2. **Caution!** - When installing the "signaling switch" refer to it's installation instructions for proper installation.
6. Plug in the power supply into a 120VAC, 50/60 HZ standard wall outlet. For UL applications, remove center screw on receptacle and place cord from wallmount transformer inside the plastic cord holder. Secure plastic cord holder to the receptacle by reinstalling screw to the center hole of receptacle. See Figure 2. For Canadian applications DO NOT INSTALL Plastic Cord Holder! The green "Normal" light should come on.
7. Test the system by pressing the "Test" switch or by activating the "signaling device". The buzzer and the red warning light will be "on". The green "Normal" light will be "off". Press the "Silence" switch. The buzzer will silence but the alarm light will remain "on". Deactivate the "signalling device." The alarm light will turn "off" and the green "Normal" light will turn "on" indicating the system is now in a normal condition. Since the VERSA'LARM is equipped with "Auto Reset", reactivating the "signaling device" for a new test cycle will reactivate the buzzer and alarm light.
8. Test product weekly to ensure system integrity.

Figure 1 - Installing/Replacing Battery

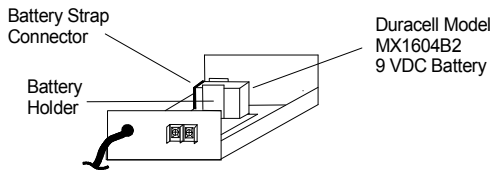

Figure 2 - Mounting

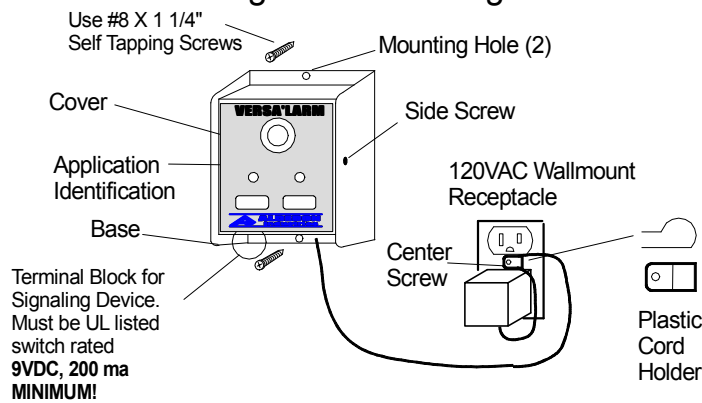

Figure 3A - Installing Field Wiring for Auxiliary Contacts

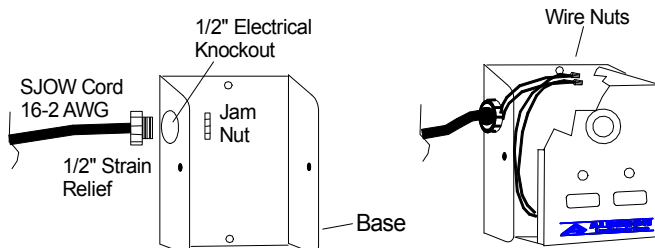
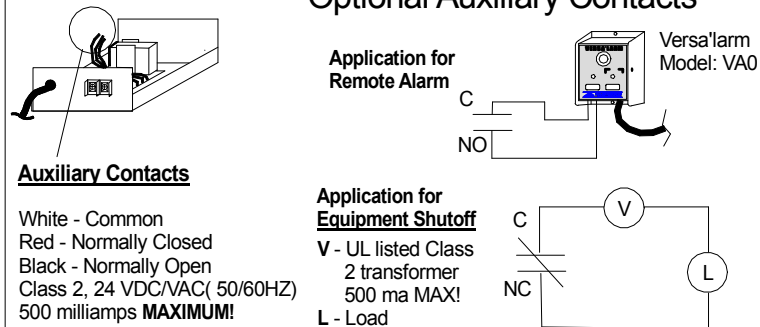
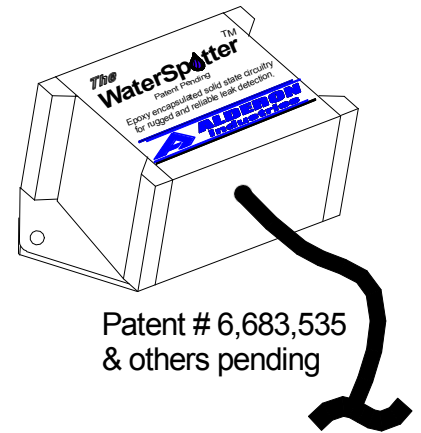

Figure 3B - Wiring Diagram for Optional Auxiliary Contacts



WaterSpotter™ Installation Instructions

Caution: Disconnect power before servicing.
Read instructions thoroughly.
Check local codes and install to meet requirements.



Part Number 7008 (15')



Specifications

Mechanical

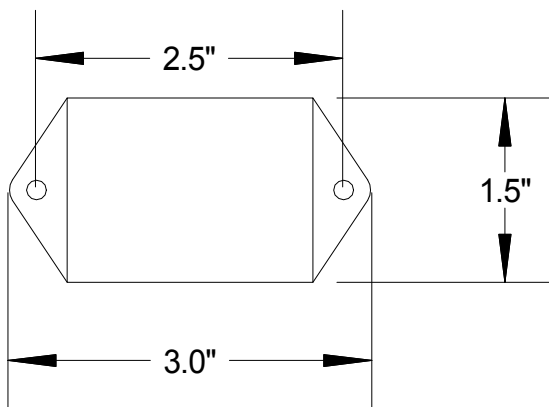

Electrical

Voltage: 9-12VDC
Operating Current: 3 ma
Switching Current: 500 ma Maximum

Model Number Nomenclature

<u>WS160</u>	<u>10</u>	<u>Cable Length Options</u>	
		10 - ten feet	30 - thirty feet
		15 - fifteen feet	40 - forty feet
		20 - twenty feet	50 - fifty feet

WaterSpotter Series 160



Description of Operation

The WaterSpotter is a reliable leak detection sensor that can be used in a wide variety of applications such as: computer rooms, basements, sumps, air conditioner condensate runover, water heaters, utility rooms, and many more applications.

The solid state circuitry is encapsulated in epoxy making the unit waterproof and tamperproof. The probes are stainless steel and will not rust. Works excellent even with distilled and condensate water.

When connected to the VERSA'LARM, a thin film of water will activate the VERSA'LARM activating the buzzer and flashing alarm light. Optional auxiliary contacts can be utilized to annunciate the alarm or wired into a control circuit that will shut the machine off to prevent further water leakage. Up to six WaterSpotter's can be connected to the VERSA'LARM for zone area protection.



Leading Edge Control Products

Alderon Industries, LLC
P.O. Box 827
Hawley, MN 56549

P/N 10082 Rev A
9/05/00
Phone: 218.483.3034
Fax: 218.483.2036



WaterSpotter™ Installation Instructions continued

1. Disconnect Power. Determine location for leak detection. See Figure 1.
2. Install the Alderon VERSA'LARM™ per Installation Instruction for the VERSA'LARM (P/N 10026 Rev A).
3. Connect the WaterSpotter to the VERSA'LARM. CAUTION! - Red wire must be connected to the "left" terminal and the Black wire must be connected to the "right" terminal. See Figure 2.
5. Place the WaterSpotter at the desired location. Optional: For a more secure mount use either the included adhesive foam tape or use screws installed through the mounting feet on the WaterSpotter.
6. In the event of water detection, completely wipe off probes before putting back into service.
7. Test product weekly. For the Versa'alarm, make sure the green "Normal" light is "on". Press the "Test" switch, the red alarm light and buzzer should turn "on". If the battery backup system is utilized, unplug the wallmount power supply (the green light will be off). Now press the "Test" switch, the red alarm light and buzzer will turn "on". If the buzzer sounds less loud then when tested with the normal power supply, then replace the battery. Refer to instructions on installing/replacing the battery on page 2 of the Versa'alarm Installation Instruction P/N 10026 Rev A. Reconnect power supply when finished to put the Versa'alarm back into service. Test the WaterSpotter by immersing the probes in water or place a wet rag or sponge across the probes. The Versa'alarm should activate. Completely wipe and dry probes before putting unit back into service. See Figure 3.

VERSA'LARM Advanced Monitoring System

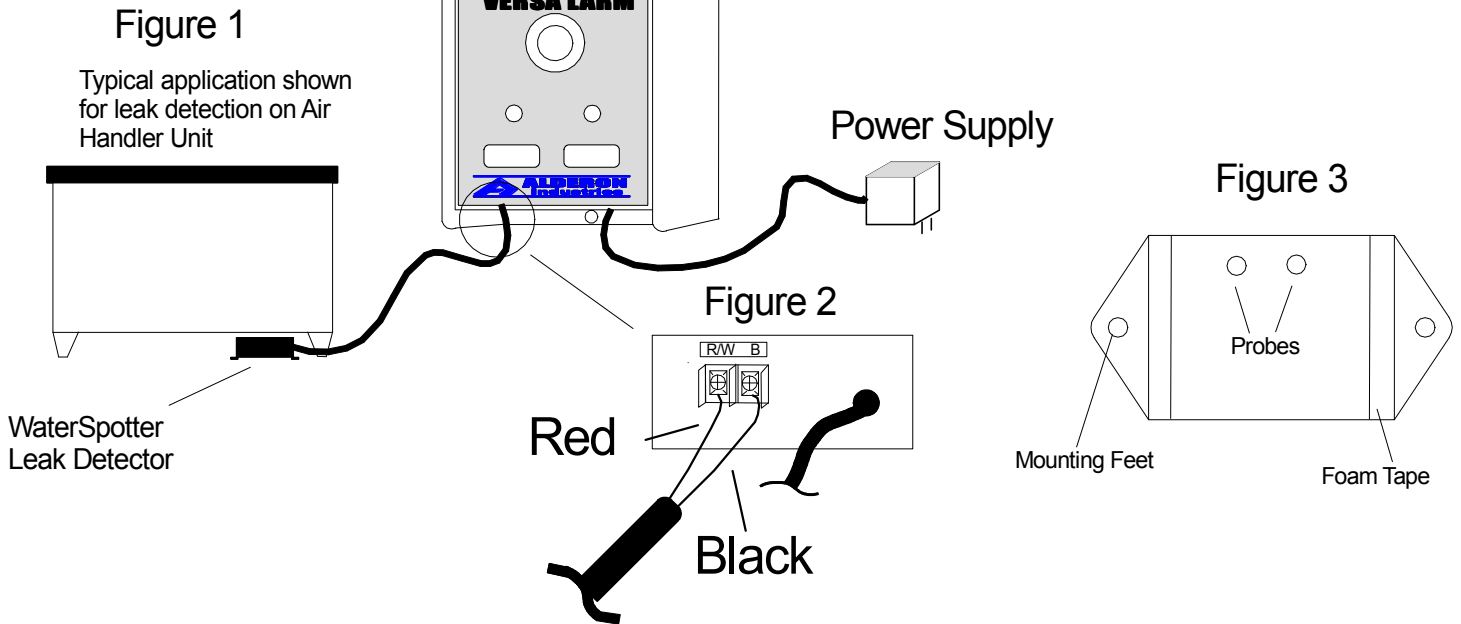

Multiple WaterSpotter's can be connected for zone protection. Maximum of **6** WaterSpotter's per each Versa'alarm monitoring system.

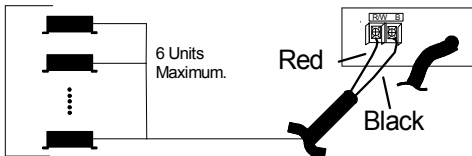

The VERSA'LARM is able to monitor multiple sensors such as a float switch and WaterSpotter Simultaneously.

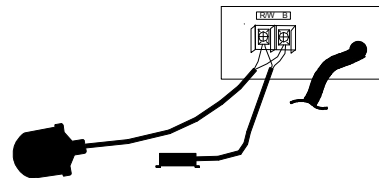

Alderon Industries, LLC
P.O. Box 827
Hawley, MN 56549

P/N 10082 Rev A
9/05/00
Phone: 218.483.3034
Fax: 218.483.3036